

GN 728

Handles

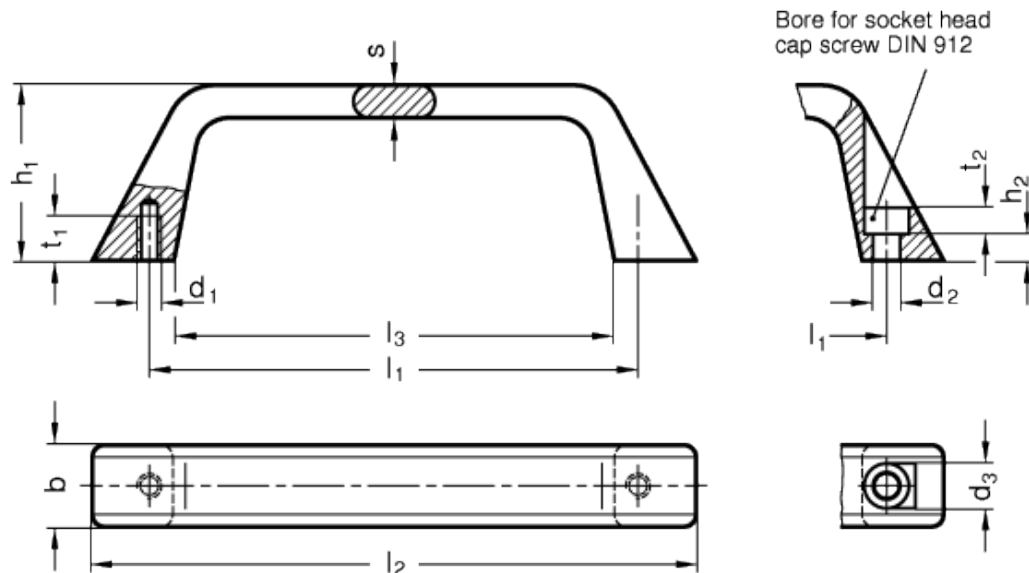

technical informations

Material

Pressure die-cast aluminium.

- Version BL: natural aluminium.
- Version SW: RAL 9005 black colour, matte finish, epoxy resin coating.
- Version SR: RAL 9006 silver colour, matte finish, epoxy resin coating.

Assembly

- Type A: back mounting, tapped blind holes.
- Type B: front mounting, through holes for cylindrical-head screws with hexagon socket, DIN 912.

Features and applications

The installation of cabinet "U" handles GN 728 can be carried out from the back (type A) as well as from the operator's side

(type B). The hole centers dimension is identical on all variants. As a result they can be mounted in pairs opposite each other.

Standard Elements	Main dimensions							Mounting holes					Weight
Description	$l_1 \pm 0.25$	b	d_3	h_1	l_2	l_3	s	d_1	d_2	h_2	$t_{1 \text{ min.}}$	t_2	g
GN 728-120-A-BL	120	22.5	11	42.5	147	108	8	M6	-	-	10	-	90
GN 728-120-A-SW	120	22.5	11	42.5	147	108	8	M6	-	-	10	-	90
GN 728-120-A-SR	120	22.5	11	42.5	147	108	8	M6	-	-	10	-	90
GN 728-120-B-BL	120	22.5	11	42.5	147	108	8	-	6.4	6.5	-	6.5	80
GN 728-120-B-SW	120	22.5	11	42.5	147	108	8	-	6.4	6.5	-	6.5	80
GN 728-120-B-SR	120	22.5	11	42.5	147	108	8	-	6.4	6.5	-	6.5	80
GN 728-180-A-BL	180	27	13.5	47.5	214	165	10	M8	-	-	12	-	185
GN 728-180-A-SW	180	27	13.5	47.5	214	165	10	M8	-	-	12	-	185
GN 728-180-A-SR	180	27	13.5	47.5	214	165	10	M8	-	-	12	-	185
GN 728-180-B-BL	180	27	13.5	47.5	214	165	10	-	8.4	7.5	-	8.5	170
GN 728-180-B-SW	180	27	13.5	47.5	214	165	10	-	8.4	7.5	-	8.5	170
GN 728-180-B-SR	180	27	13.5	47.5	214	165	10	-	8.4	7.5	-	8.5	170



ELESA and GANTER models all rights reserved in accordance with the law. Always mention the source when reproducing our drawings.

STANDARD MACHINE ELEMENTS WORLDWIDE